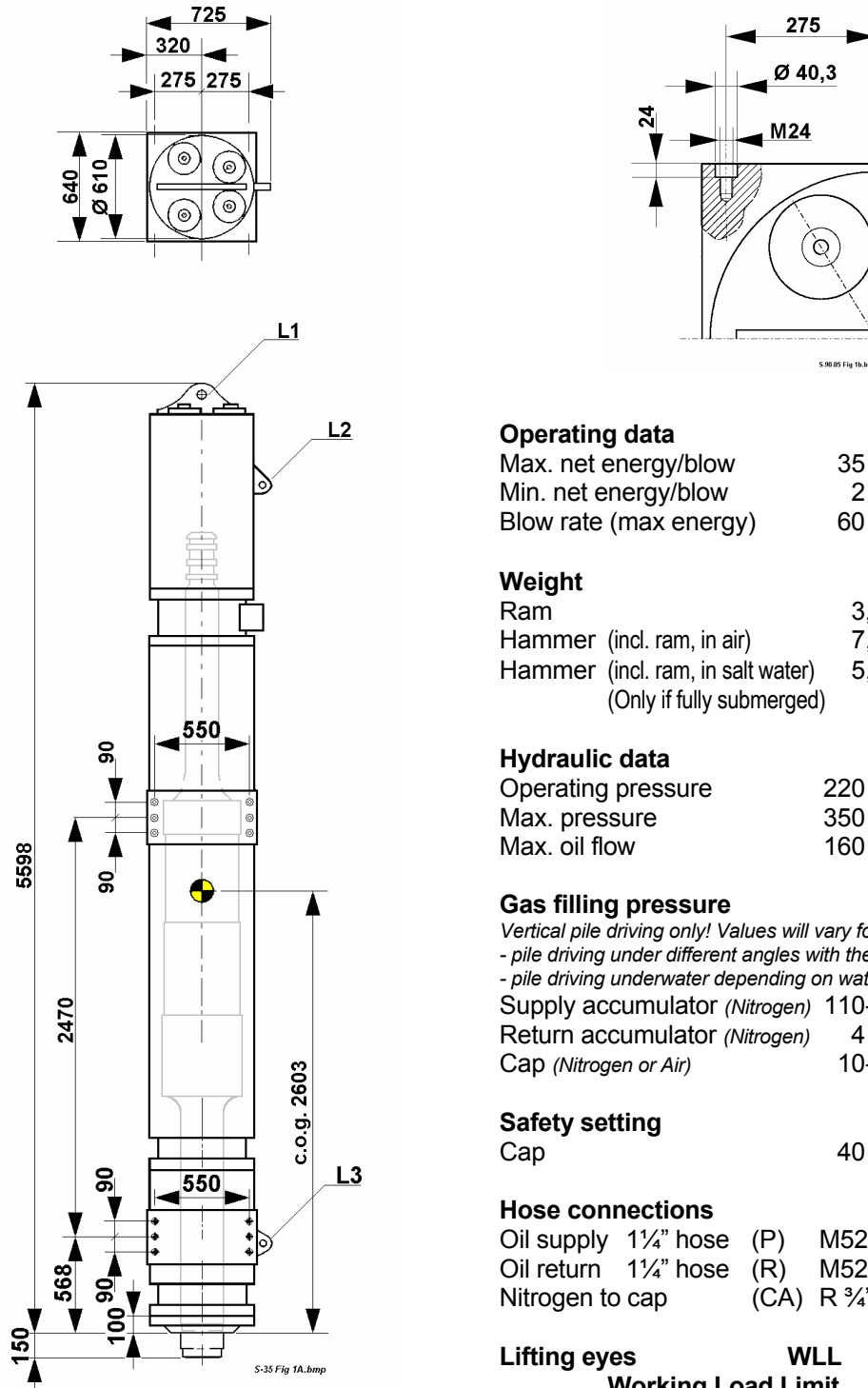

APPLICATION: Steel piles.
Code no. 85.09.00.01

Main dimensions
Operating data

Max. net energy/blow	35	kNm
Min. net energy/blow	2	kNm
Blow rate (max energy)	60	Blows/min

Weight

Ram	3,0	tons
Hammer (incl. ram, in air)	7,1	tons
Hammer (incl. ram, in salt water)	5,5	tons
(Only if fully submerged)		

Hydraulic data

Operating pressure	220	bar
Max. pressure	350	bar
Max. oil flow	160	l/min

Gas filling pressure

Vertical pile driving only! Values will vary for:
- pile driving under different angles with the vertical,
- pile driving underwater depending on water depth.

Supply accumulator (Nitrogen)	110-130	bar
Return accumulator (Nitrogen)	4 - 5	bar
Cap (Nitrogen or Air)	10-12	bar

Safety setting

Cap	40	bar
-----	----	-----

Hose connections

Oil supply	1 1/4" hose (P)	M52x2	male
Oil return	1 1/4" hose (R)	M52x2	male
Nitrogen to cap	(CA)	R 3/4"	male

Lifting eyes

	WLL	hole diam.	thick ness
L1	20 tons	Ø52mm	70mm
L2 / L3	9 tons	Ø40mm	40mm