



491 Conroe Park W. Dr. • Conroe, TX 77303

Specifications: D 8-52 Diesel Pile Hammer

Dimensions approx:

Length of Hammer:	A 1	4700 mm	15FT 5IN
Hammer length w/starter guides:	A	5200 mm	17FT 1IN
Outer diameter of impact block:	B	350 mm	1FT 2IN
Min. Guiding Width:	C	533 mm	21IN
Width of hammer:	D	410 mm	16IN
Hammer Center to Pump Guard:	F	315 mm	1FT
Hammer Center to Trip:	G	245 mm	9.6IN
Hammer Depth:	H	590 mm	1FT 11IN

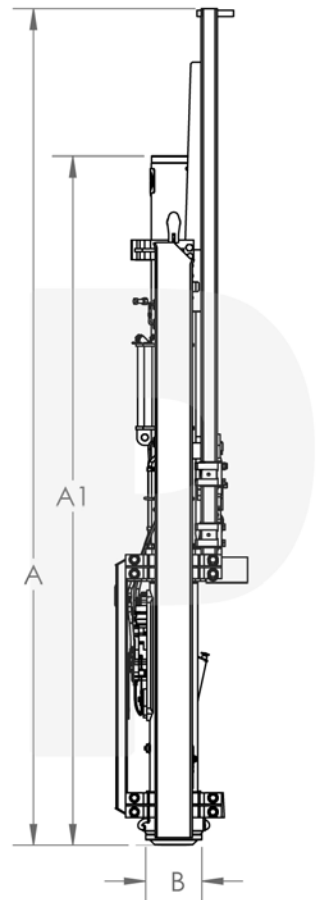

VIEW PARTS MANUAL HERE

Pump Setting 1	12.9 kNm	9,480 ft.lbs.
Pump Setting 2	16.9 kNm	10,350 ft.lbs.
Pump Setting 3	21.1 kNm	15,570 ft.lbs.
Pump Setting 4	25.4 kNm	18,760 ft.lbs.

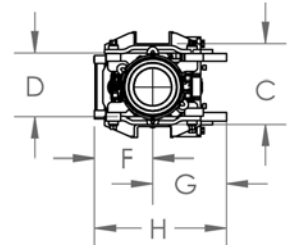

Weights approx:

Weight of diesel pile hammer approx.:	3.03 US Tons	6,076 lbs
Weight of piston approx.:	800 kg	1,768 lbs
Impact Block approx.:	185 kg	408 lbs
Tripping device approx.:	160 kg	353 lbs
Tool box approx.:	75 kg	165.35 lbs

Energy per blow

Max:	25.4 kNm	18,760 ft lbf
Min:	12.9 kNm	9,480 ft lbf
Number of blows:	37-52 min	
Suitable for driving piles, up to	3,000 kg	6,614 lbs

Batter Info

Max. gradient of batter pile driven:	1:2
--------------------------------------	-----

Consumption

Diesel fuel:	3.8 L hr.	1 gph
Lubrication oil:	.5 L hr.	.13 gph

Volume

Diesel oil tank:	20 L	5.08 gal
Lube tank:	6 L	1.59 gal

