

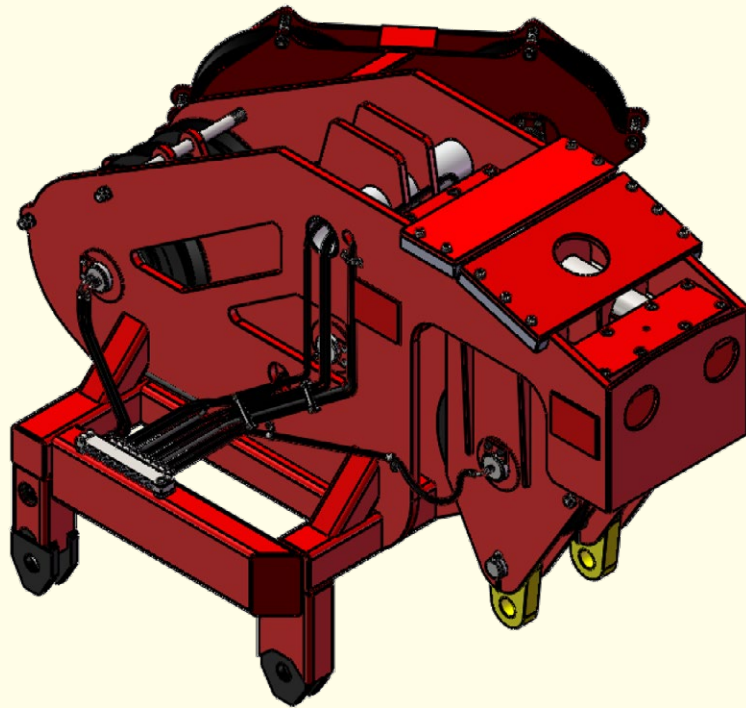

PILECO INC.

**8000374 U-42 Head Block with Revolving
Fairleads and Auger Sheaves**
Parts Manual

Parts Manual



**U-42 HEAD BLOCK WITH REVOLVING FAIRLEAD
AND AUGER BRACKET**

pages 3–9

LUBRICATION MAINTENANCE

page 10

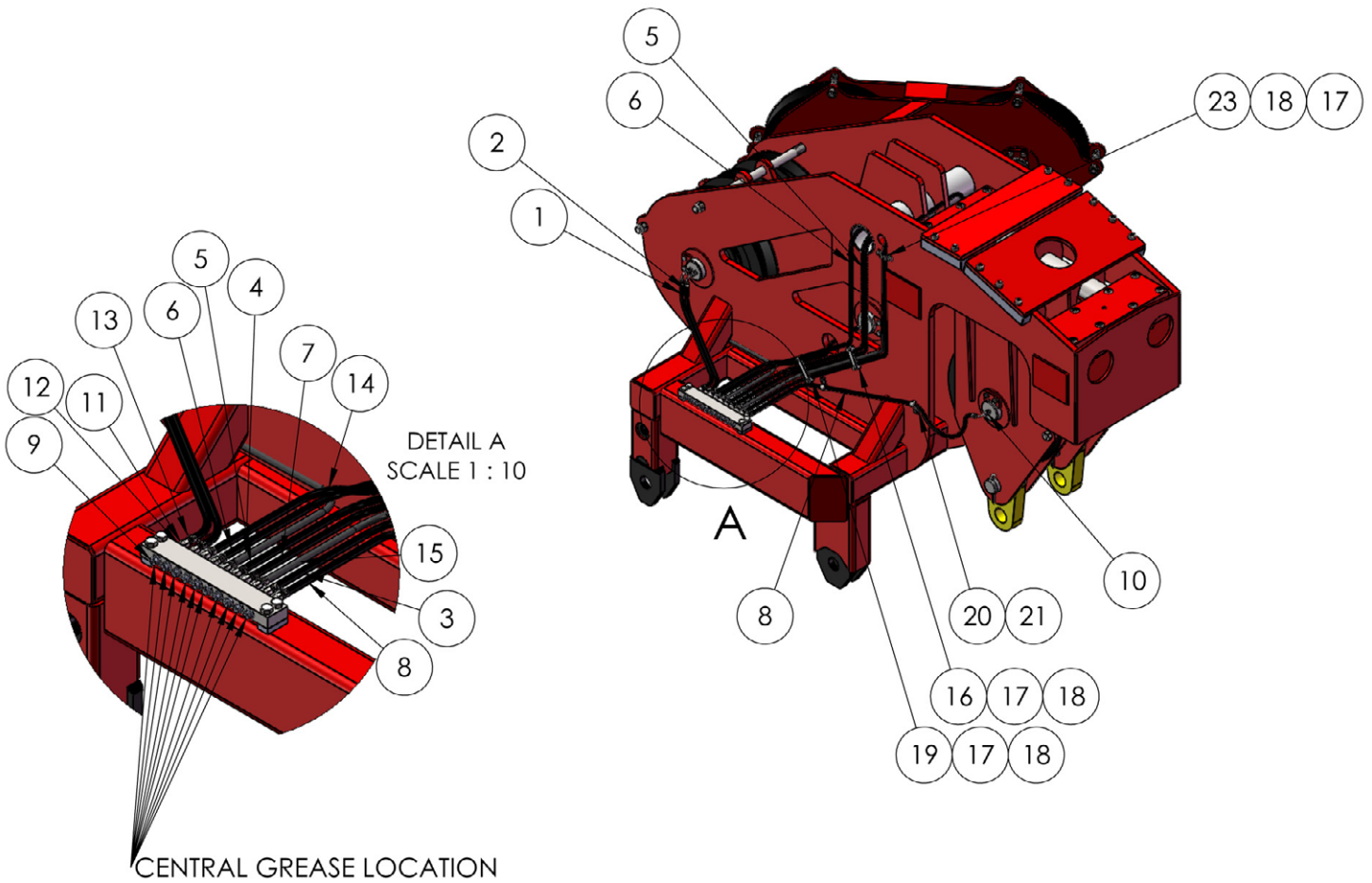
U-42 HEAD BLOCK WITH REVOLVING FAIRLEAD AND AUGER BRACKET

CONTINUED....

U-42 HEAD BLOCK WITH REVOLVING FAIRLEAD AND AUGER BRACKET

ITEM NO.	PART NUMBER	DESCRIPTION	QTY.
1	301011	6MM DIA HOSE L=500MM	1
2	301012	6MM DIA HOSE L=500MM	1
3	301017	6MM DIA HOSE L=2010MM	1
4	301013	6MM DIA HOSE L=1480MM	1
5	8000850	6MM DIA HOSE	1
6	8000851	6MM DIA HOSE	1
7	301015	6MM DIA HOSE L=3200MM	1
8	301018	6MM DIA HOSE L=1800MM	1
9	90791	GREASE NIPPLE M10 X 1	10
10	301010	90DEG FITTING 3CF82-6-4	7
11	301002	3CA82-6-4 STRAIGHT FITTING	13
12	301001	STRAIGHT FITTING GE06L1/8NPTOMDA3C	20
13	95115	HOSE CLAMP 1/4-5/8	19
14	301014	6MM DIA HOSE L=865MM	1
15	301016	6MM DIA HOSE L=1710MM	1
16	301006	4 SLOT HOSE BRACKET	1
17	55127	8MM SPLIT LOCKWASHERS	6
18	55128	8MM-1.25 X 30 HEX HEAD CAPSCREW	6
19	301003	5 SLOT HOSE BRACKET	1
20	301008	CLIP	3
21	301009	8MM X 16MM HEX HEAD CAP SCREW	3
22	90637	8 X 80 COTTER PIN	1
23	301007	HOSE BRACKET	1

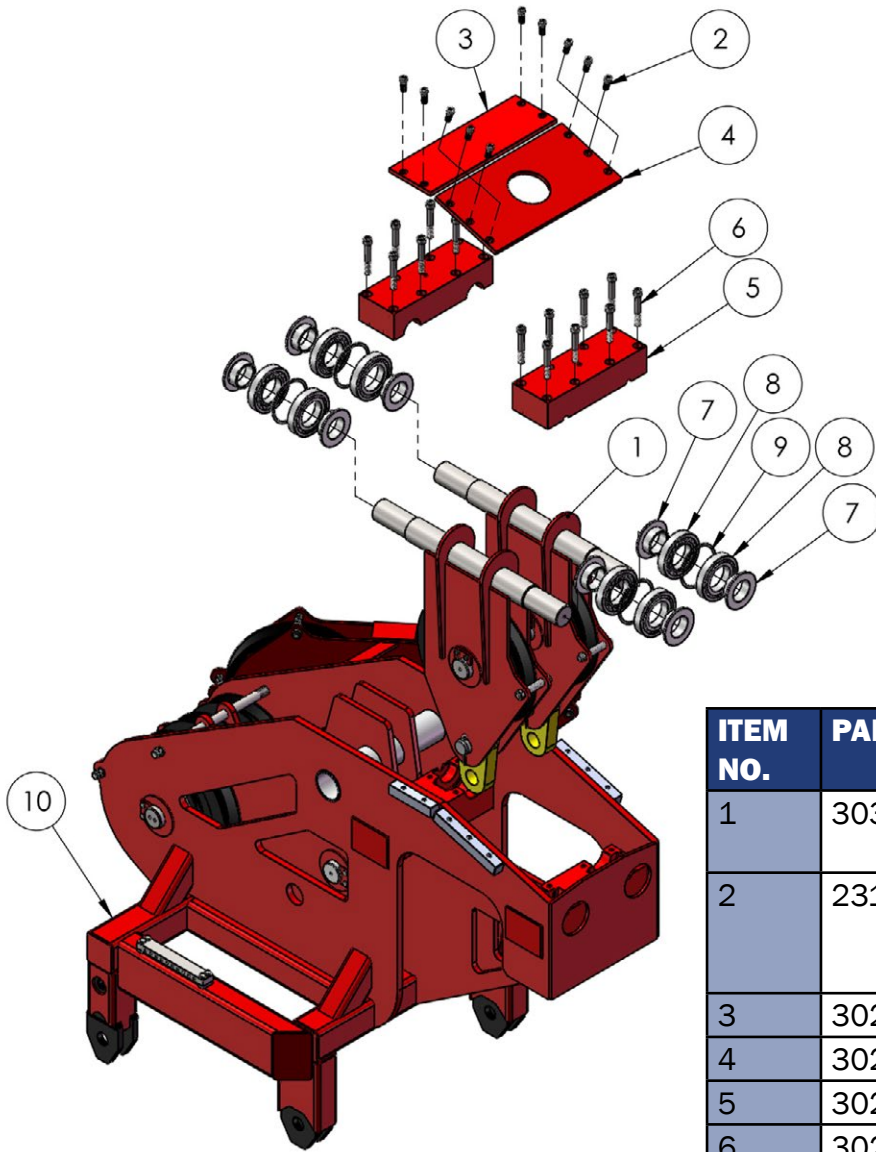
U-42 HEAD BLOCK WITH REVOLVING FAIRLEAD AND AUGER BRACKET

ITEM NO.	PART NUMBER	DESCRIPTION	QTY.
1	30300	REVOLVING FAIRLEADS	1
2	231603	16MM-2 X 50MM SOCKET HEAD CAP SCREW	10
3	302008	COVER PLATE	1
4	302009	COVER PLATE	1
5	302011	LOCKING BLOCK	2
6	302010	3/4-10 X 5 SOCKET HEAD CAP SCREW	16
7	303013	BEARING SLEEVE	8
8	303014	NJ219E BEARING	8
9	302006	SPACER	4
10	8000849	U-32 4 LINE HEADBLOCK WITH REVOLVING FAIRLEADS WITH AUGER BRACKETS WELDED FRAME	1

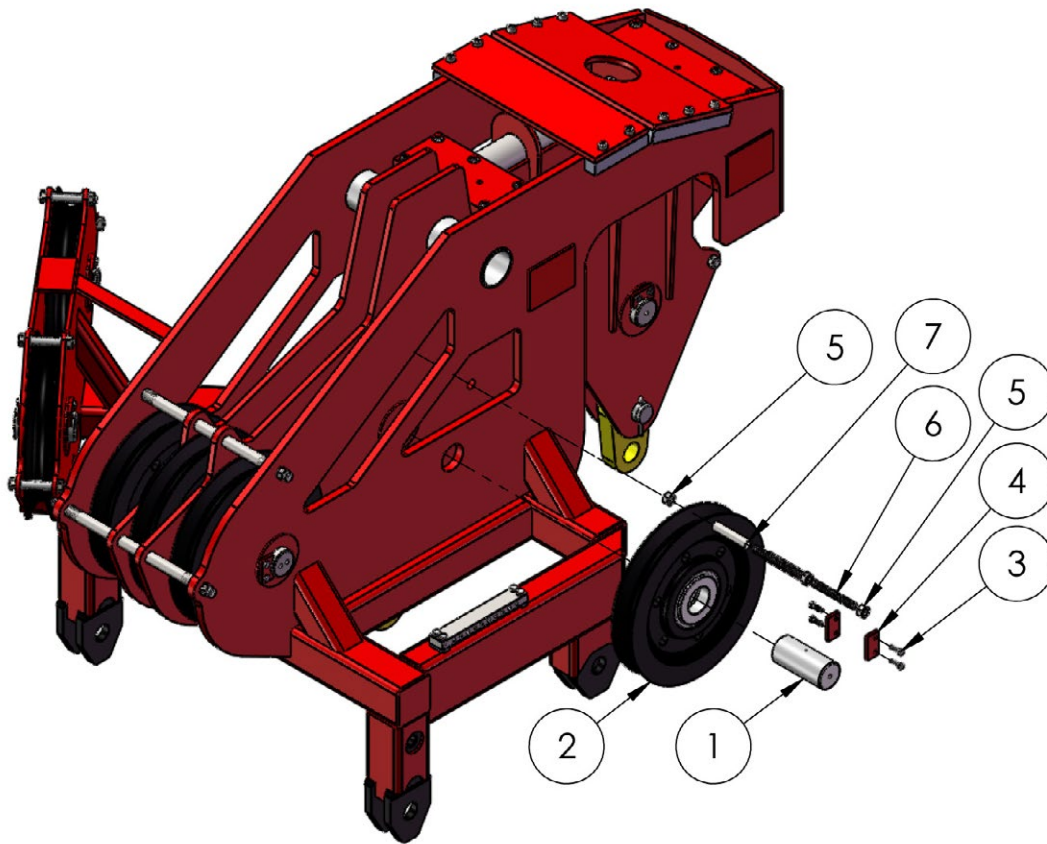
U-42 HEAD BLOCK WITH REVOLVING FAIRLEAD AND AUGER BRACKET

ITEM NO.	PART NUMBER	DESCRIPTION	QTY.
1	302019	SHAFT	1
2	303011	SHEAVE	1
3	302012	10-1.5 X 35 HEX HEAD CAPSCREW 8.8	4
4	302013	LOCKING PLATE	2
5	303010	3/4-10 HEX NUT	2
6	302021	3/4-10 X 7 ALL THREAD	1
7	302017	1" SCH 40 PIPE	1

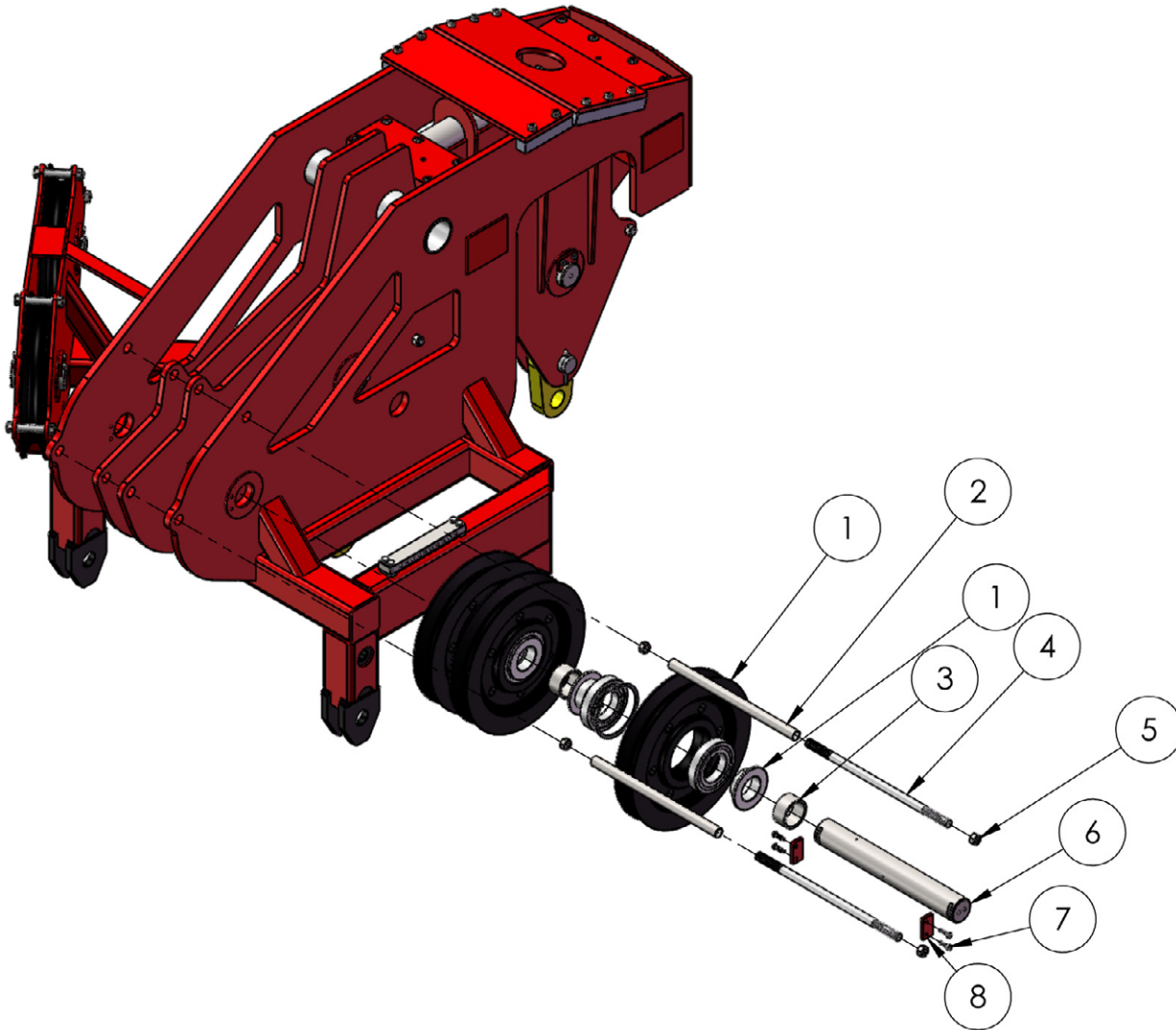
U-42 HEAD BLOCK WITH REVOLVING FAIRLEAD AND AUGER BRACKET

ITEM NO.	PART NUMBER	DESCRIPTION	QTY.
1	303011	SHEAVE	3
2	302002	1" SCH 40 PIPE	2
3	302001	SPACER	4
4	302004	3/4-10 ALL THREAD ROD	2
5	303010	3/4-10 HEX NUT	4
6	302014	SHAFT	1
7	302012	10-1.5 X 35 HEX HEAD CAPSCREW 8.8	4
8	302013	LOCKING PLATE	2

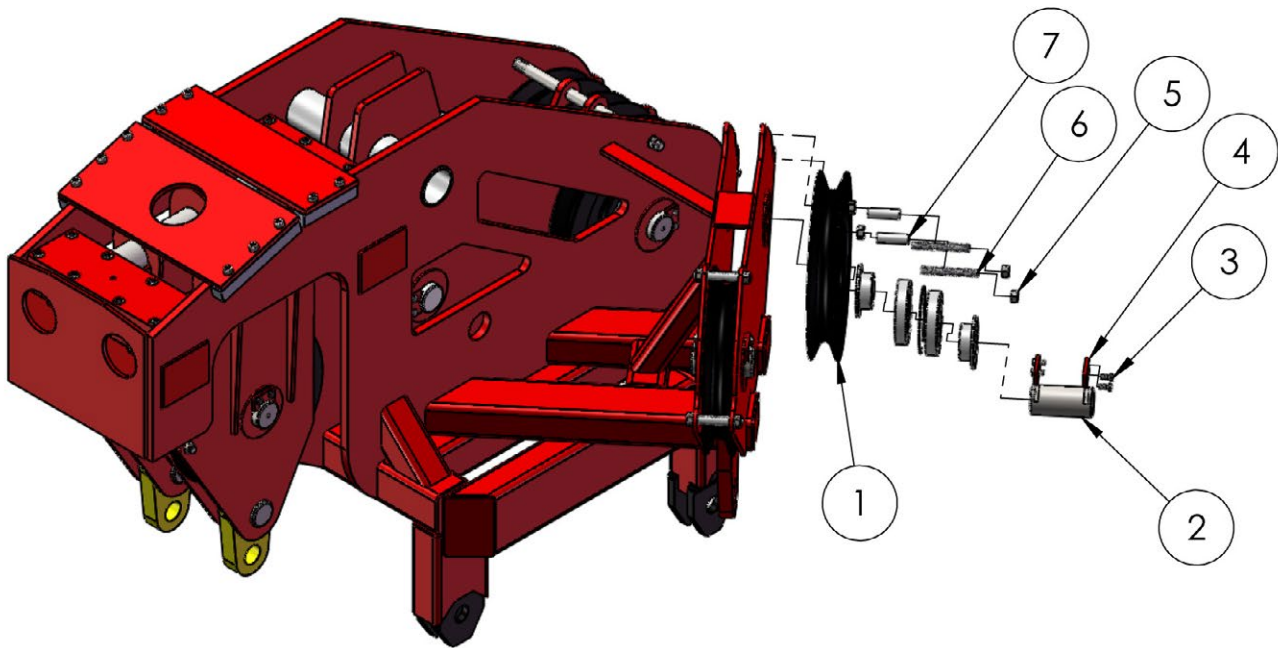
U-42 HEAD BLOCK WITH REVOLVING FAIRLEAD AND AUGER BRACKET

ITEM NO.	PART NUMBER	DESCRIPTION	QTY.
1	303011	SHEAVE	2
2	303002	SHAFT	2
3	8000842	12MM-1.75 X 25 HEX HEAD CAP SCREW	8
4	303003	LOCKING PLATE	4
5	303010	3/4-10 HEX NUT	4
6	303009	3/4-10 X 6" ALL THREAD ROD	2
7	303008	SCH 40 PIPE	2

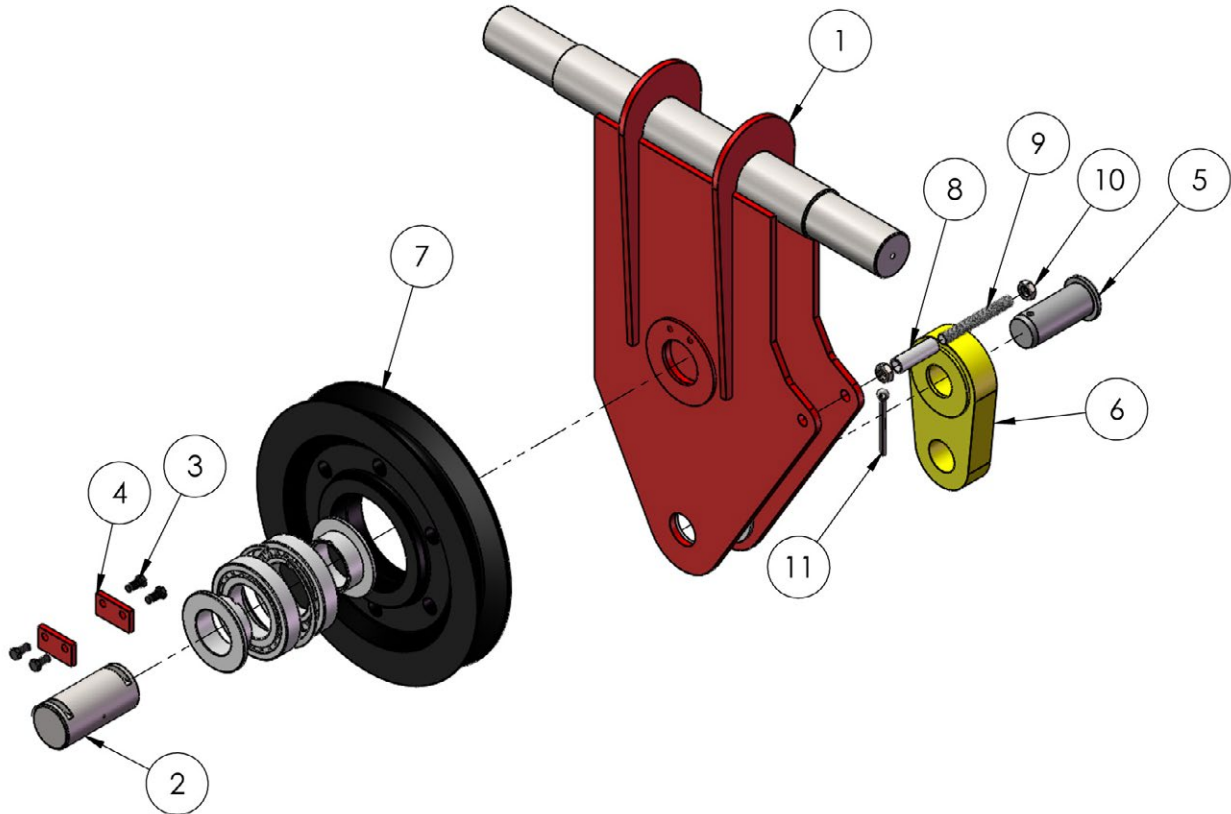
U-42 HEAD BLOCK WITH REVOLVING FAIRLEAD AND AUGER BRACKET

ITEM NO.	PART NUMBER	DESCRIPTION	QTY.
1	303001	REVOLVING FAIRLEAD FRAME	1
2	303002	SHAFT	1
3	301009	8MM X 16MM HEX HEAD CAP SCREW	4
4	303003	LOCKING PLATE	2
5	303005	PIN	1
6	303006	PADEYE	1
7	303011	SHEAVE	1
8	303008	SCH 40 PIPE	1
9	303009	3/4-10 X 6" ALL THREAD ROD	1
10	302005	3/4-10 HEX JAM NUT	2
11	303007	10 X 100 COTTER PIN	1

Visual Inspections

1. All equipment shall be checked every 6 months for wear and cracks
2. Check all welds for cracking and fatigue
3. Bearings shall be inspected for unusual wear and replaced if needed
4. Hoses shall be replaced if cracks or leakage occur

**RECOMMENDED LUBRICANT:
MOBILITH SHC 220 GREASE**

LUBRICATION MAINTENANCE SCHEDULE:	DAILY	6 MONTHS	ANNUALLY
GREASE ALL SHEAVES	•		
REPACKING OF BEARINGS			•

REPACKING OF BEARINGS MUST BE DONE MANUALLY. PLEASE REFER TO SKF FOR PROPER PACKING OF BEARINGS.